

Myriad Design

MUPV1 Unbalanced Piezo Preamp

(SKU SV202)

User Guide V1.0 – December 2016

Note:

The Unbalanced Piezo Preamp Module has been hand soldered using a proprietary no-clean-flux solder. This is so we do not have to use environmentally unsatisfactory solvents to clean flux residue from the printed circuit board.

There is no need to clean the circuit board further.

Copyright 2012-16 Myriad Design. All rights reserved.

Disclaimer.

The information contained herein is provided in good faith. Myriad Design has no control over the way the design is implemented or integrated into a system. Therefore, Myriad Design offers no actual or implied warranty of fitness for purpose and Myriad Design will accept no liability for consequential loss or damage. This design is not authorised for use in any safety-critical system. Your statutory rights are not affected.

Myriad Design

Unbalanced Piezo Preamp MUPV1

User Guide V1.0 - December 2016

Thank you for purchasing the MUPV1 Unbalanced Piezo Preamp module.

The preamp is designed for integration into a musical instrument to buffer the output of a piezo transducer element. The preamp is professionally hand-built and the JFET transistors are very closely matched. The preamp has very low distortion and noise.

The output voltage of a piezo is comparatively large but its output impedance is very high. The preamp has unity voltage-gain and provides current-gain to lower the output impedance of the piezo to allow it to drive a significant length of cable without loss of high-frequency signal.

The unit must be connected to a mixing desk, DAW or combo/amplifier instrument input using a standard unbalanced 1/4" Jack lead (guitar lead). The unit also requires a power supply which may be derived from a standard 9V battery or a regulated, smoothed d.c. power supply with a voltage between 4V and 24V. A power supply voltage between 9V and 18V is recommended. The unit powers up only when a 2-pole jack is plugged into the output.

The module should be located as close to the piezo transducer as is practical.

If the module is incorporated into a wooden case such as a stomp box, cigar box guitar, or cajon, you must create a shielded environment for the module and the piezo element.

For further information on shielding, search YouTube for "shielding a guitar".

The piezo element (the brass disc) should be in electrical contact with the shielding and/or the shielding should be connected to GND.

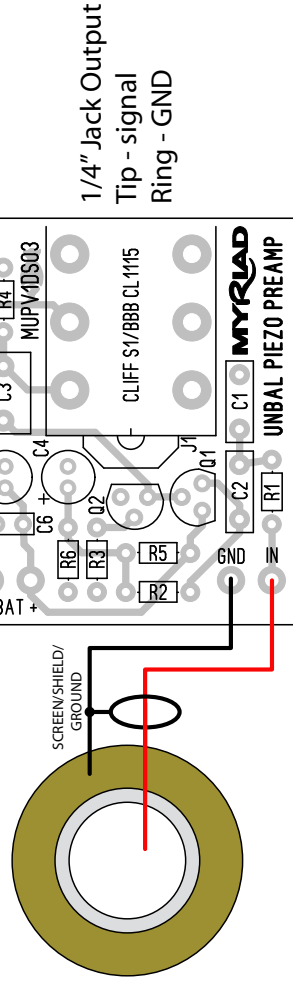

Connect the piezo transducer to IN and GND on the input connector. If you have a bare transducer, connect the brass disc to GND.

The preamp module is physically supported by the output connector. There is no need for additional support for the preamp circuit board.

Panel cut-out 11mm Ø hole (7/16")

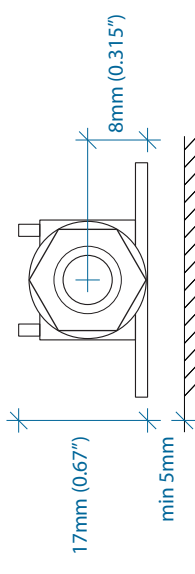

Allow minimum 5mm (0.2") clearance between the bottom of the PCB and the enclosure

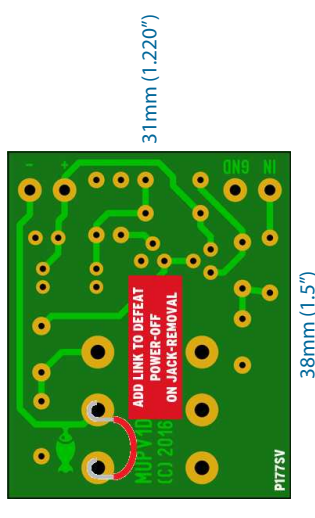

Selecting a Piezo Transducer

Piezo transducers come in different sizes. Generally, the larger the diameter, the better the low-frequency response.

The Murata 7BB-35-3 is a good starting point for a cajon or stompbox.

Using The Preamp

Piezo transducers have good frequency response and high output voltage. The preamp will drive at least 20m of cable without significant high-frequency loss.

- Connect the unit to a battery or power supply.
- Connect the unit to an input on your mixing desk/DAW/amplifier.
- Consider using the pad (if available and if necessary) to avoid overloading the preamp.
- Use equalisation (EQ) to alter the tonal quality.
- Use a limiter and/or compressor to reduce the dynamic range or avoid overloads.